

REMOVAL AND INSTALLATION

Coolant Pump — 4.6L (3V)

Material

Item	Specification
Motorcraft Premium Gold Engine Coolant VC-7-A (in California, Oregon and New Mexico VC-7-B, in Canada CVC-7-A) or equivalent (yellow color)	WSS-M97B51-A1

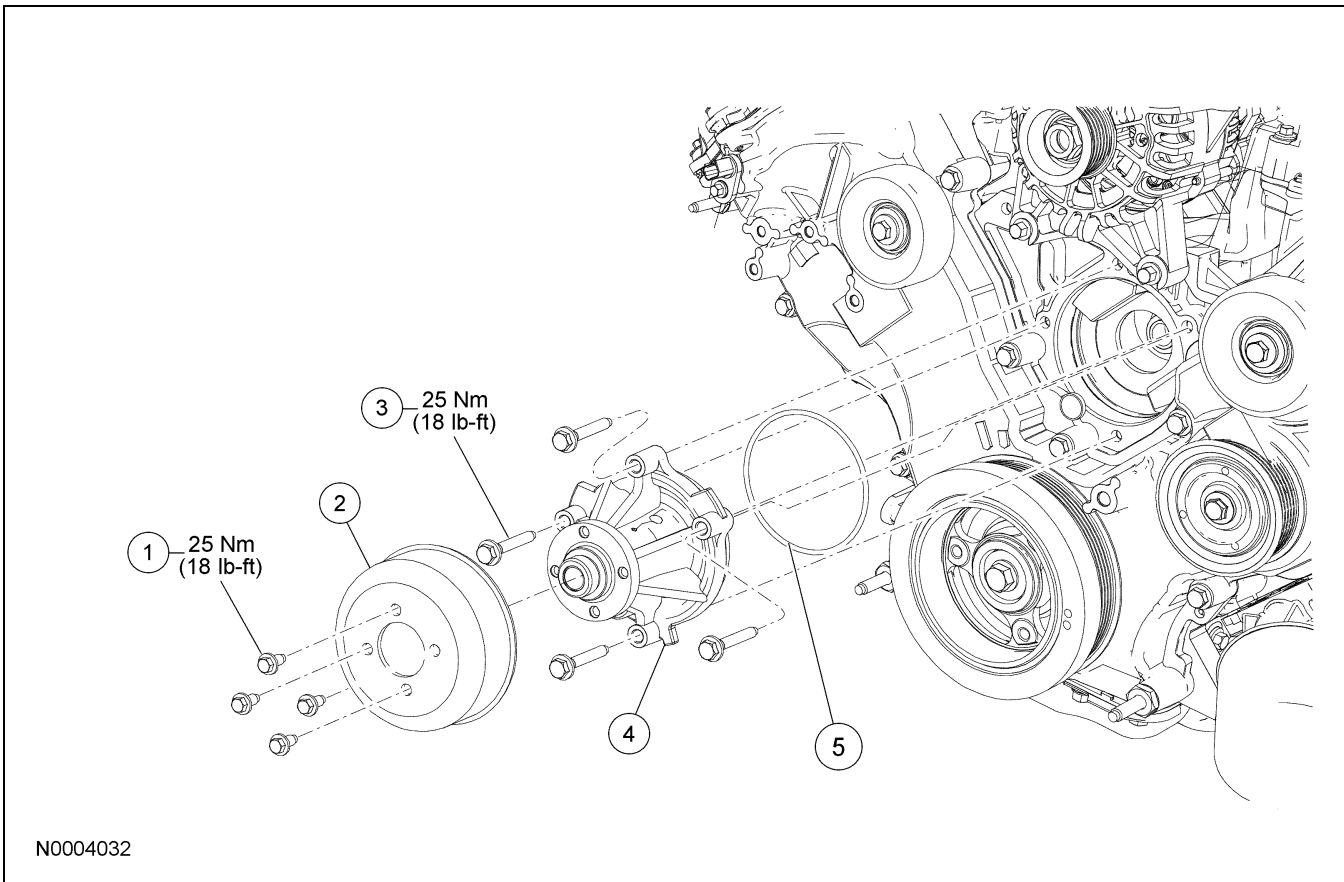

Item	Part Number	Description
1	N80628	Coolant pump pulley bolt (4 required)
2	A8528	Coolant pump pulley
3	N806177	Coolant pump bolt (4 required)
4	8501	Coolant pump
5	—	Coolant pump O-ring seal

Removal and Installation

1. Drain the engine cooling system. For additional information, refer to Cooling System Draining, Filling and Bleeding in this section.
2. Remove the air cleaner outlet pipe. For additional information, refer to Section 303-12.
3. Loosen the 4 coolant pump pulley bolts.

REMOVAL AND INSTALLATION (Continued)

4. Remove the accessory drive belt. For additional information, refer to Section 303-05.
 5. Remove the 4 coolant pump pulley bolts and the coolant pump pulley.
 - To install, tighten to 25 Nm (18 lb-ft).
 6. Remove the 4 coolant pump bolts and the coolant pump.
 - Discard the coolant pump O-ring seal.
 - To install, tighten to 25 Nm (18 lb-ft).
 7. To install, reverse the removal procedure.
 - Install a new coolant pump O-ring seal and lubricate with clean engine coolant.
 8. Fill and bleed the cooling system. For additional information, refer to Cooling System Draining, Filling and Bleeding in this section.
-