

REMOVAL AND INSTALLATION

Brake Caliper

Material

Item	Specification
High Performance DOT 3 Motor Vehicle Brake Fluid PM-1 (Canada CPM-1)	ESA-M6C25-A

Removal

⚠ WARNING: Use of any other than approved DOT 3 motor vehicle brake fluid will cause permanent damage to brake components and will render the brakes inoperative. Failure to follow these instructions may result in personal injury.

⚠ WARNING: Brake fluid contains polyglycol ethers and polyglycols. Avoid contact with eyes. Wash hands thoroughly after handling. If brake fluid contacts eyes, flush eyes with running water for 15 minutes. Get medical attention if irritation persists. If taken internally, drink water and induce vomiting. Get medical attention immediately. Failure to follow these instructions may result in personal injury.

⚠ CAUTION: Brake fluid is harmful to painted and plastic surfaces. If brake fluid is spilled onto a painted or plastic surface, immediately wash it with water.

1. With the vehicle in NEUTRAL, position it on a hoist. For additional information, refer to Section 100-02.
2. Remove the retaining clip and the parking brake cable and conduit from the brake caliper.

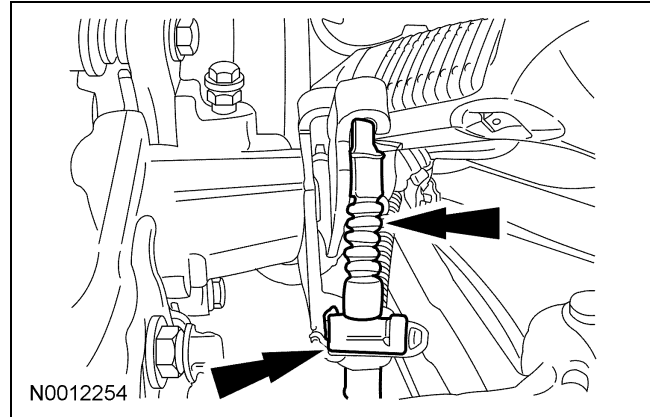

3. Remove the brake caliper flow bolt and discard the 2 copper washers.
4. Remove the 2 bolts and the brake caliper.
5. Inspect the brake caliper.
 - If leaks or damaged boots are found, install a new brake caliper.

Installation

1. Position the brake caliper and install the 2 bolts.
 - Tighten to 33 Nm (24 lb-ft).
2. Using 2 new copper washers, position the front brake flexible hose on the brake caliper and install the flow bolt.
 - Tighten to 70 Nm (52 lb-ft).
3. Connect the parking brake cable and conduit to the brake caliper.
 - Install the retaining clip.
4. Bleed the caliper. For additional information, refer to Section 206-00.